

输出功率: 约0.1~0.8W

贵金属电刷马达

典型应用: 视听设备
精密仪器
家用电器

OUTPUT: APPROX 0.1~0.8W

Precious Metal-brush Motors/Carbon-brush Motors

Typical Applications: Audiovisual Equipment
Precision Instrument
Household Appliances

1. OUTLINE DRAWING:

UNIT:MM

DIRECTION OF ROTATION

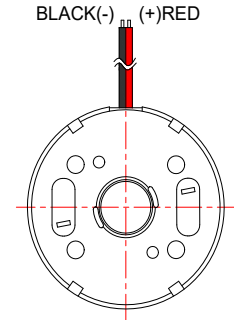
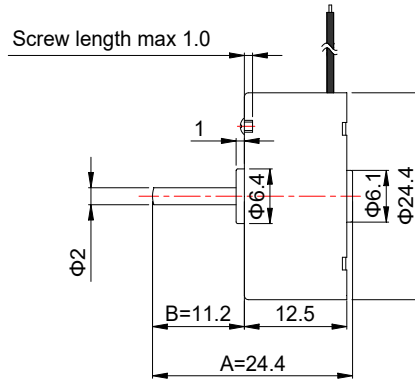
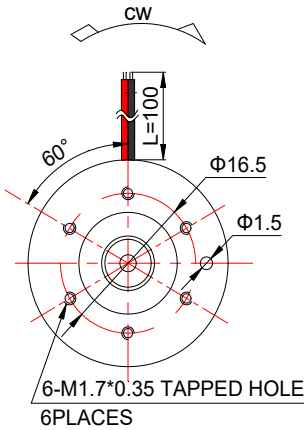

Customizable Parameters:

1. Length A, B and L
2. Electric Performance
3. Direction of Rotation
4. Eccentric Wheel is available

WEIGHT: 22g(Approx)

View:

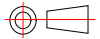

2. MOTOR PERFORMANCE :

MODEL	VOLTAGE		NO LOAD		AT MAXIMUM EFFICIENCY					STALL		
	OPERATING RANGE	NOMINAL V	SPEED rpm	CURRENT A	SPEED rpm	CURRENT A	TORQUE g.cm	TORQUE mN.m	OUTPUT W	TORQUE g.cm	TORQUE mN.m	CURRENT A
RF-300CA-11440	2.0~5.0	4.0	4700	0.04	3558	0.11	5.1	0.50	0.19	21	2.06	0.34
RF-300CA-12350	2.0~4.0	3.0	4300	0.03	3278	0.11	4.8	0.47	0.16	20	1.96	0.36
RF-300CA-09550	2.0~4.0	3.0	2600	0.03	1980	0.042	3.2	0.31	0.06	13.5	1.32	0.14

